

Membrane Pumps
Solids Handling Pumps
High Pressure Pumps
Marine Pumps

www.serviceprocess.net

Service Process Equipment, Inc.

PO Box 850908

Mobile AL 36685-0908

251.342.1313•Fax 251.342.1377

Email msellers@serviceprocess.net

ABEL EM

Electromechanical Membrane Pumps
Energy Saving PD Performance
for Process and Transfer

Like an Air Pump but:
DCS & VFD control
95% efficient
Pumps dry - no damage !
No seals - no leaks
Self Priming



Versatility, Efficiency, and Dependability

ABEL[®]
Pump Technology

Capacity up to 530 GPM, Pressure up to 115 PSI

Specialization Creates Know-How

The EM Series pump technology of ABEL is unique. It is a field proven replacement, and first choice alternative serving a diverse range of critical customer needs in process and transfer applications.

The EM Series pumps incorporate the sealless, dry-running, low shear, versatile fluid handling capability of traditional diaphragm pump design with added value including:

- ▲ Highly efficient electric drive
- ▲ Constant flow rates against variable pressure and viscosity
- ▲ Slower stroke rates for comparable volume yield lower operating costs
- ▲ 6" Port size for maximum flow rate
- ▲ Fully enclosed membranes - with no material exposure
- ▲ Fluid containment without adding bulk or additional components
- ▲ Optional VFD flow control for true process performance
- ▲ Optional pulsation dampeners and other accessories

The EM Series is also a viable alternative for expensive, sometimes space-consuming pump technologies for which the continuing cycle of maintenance costs can far exceed the original cost of the pump. Viscous, solids-containing, aggressive, and/or corrosive fluids have been less a source of concern for those who commonly return to ABEL for their challenging applications. One reason is ABEL's "Know-How" as much as product reliability.

Powder transfer with the EM Series is also available to simplify transfer of powders that "fluidize."

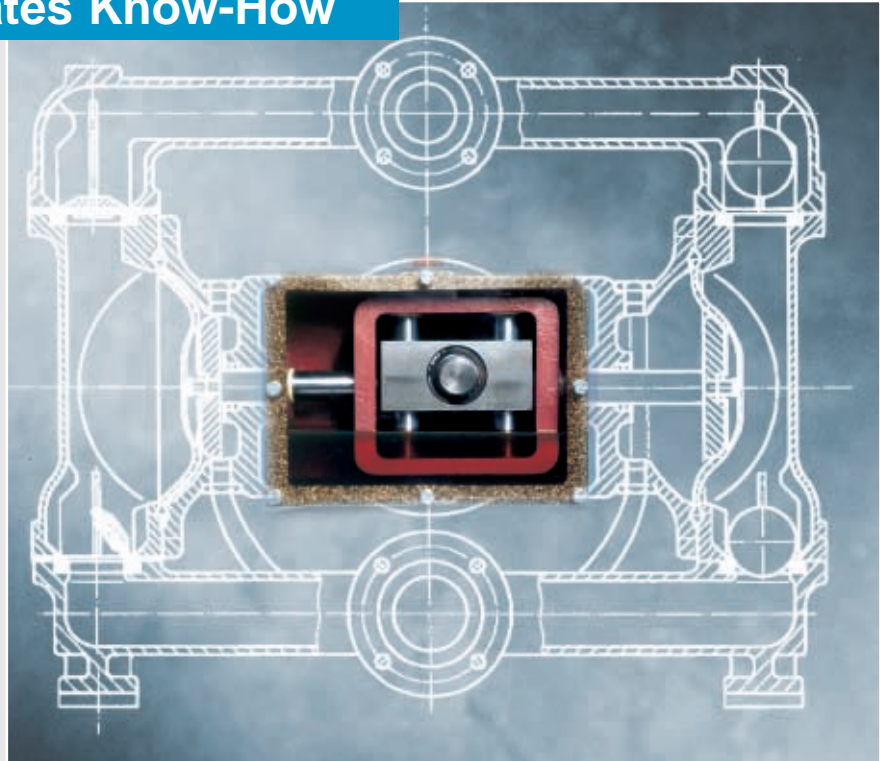

Design

The EM pump series are all electromechanical double-acting membrane (diaphragm) pumps of robust process construction. The integral metal core of each membrane is completely covered by the membrane material on its fluid pumping side, minimizing the possibility of fluid contamination.

The smooth mechanically controlled linear drive of the membranes ensures low shear, seal-less, positive displacement performance with controlled transfer rates through variable viscosity and system pressure changes.

Variable flow control is realized through a variable frequency drive (VFD) as a stand-alone device or controlled by customer system controls. Alternatively mechanical speed devices can provide for a range of variable flow.

Maximum discharge pressure can be limited by an external electrical control device, such as, a pressure switch or current limiting panel when required for additional protection.

Optional discharge dampeners and suction stabilizers are available to minimize flow pulsations under variable or demanding system conditions that would otherwise decrease performance and/or operating life of the equipment.

ABEL EM - Electromechanical Membrane Pumps

Capacity ranges to 530 GPM, Pressures to 115 PSI

How used?

- As process and transfer pumps for:
 - sludge
 - slurries
 - corrosives
 - powders
- For feeding applications of
 - filter press
 - centrifuge
- Metering
- Oil-water separation.

Where used?

- Wastewater & sewage Treatment
- Chemical
- Ceramic Manufacturing
- Mining
- Power Plants
- Paint and Coatings
- Marine and offshore
- Pulp & Paper
- Pharmaceutical
- Refineries
- Breweries
- Food Processing

Reduced Life Cycle Cost

The patented Electromechanical Membrane Pump, ABEL EM is recognized as the world market leader* in its class.

The use of conventional pumps in a range up to 115 PSI often incurs high running costs.

Running cost is only a fraction of the total life cycle cost of a pump. See the graph illustration.

* Hydraulic Institute 1999



EM Selection Chart

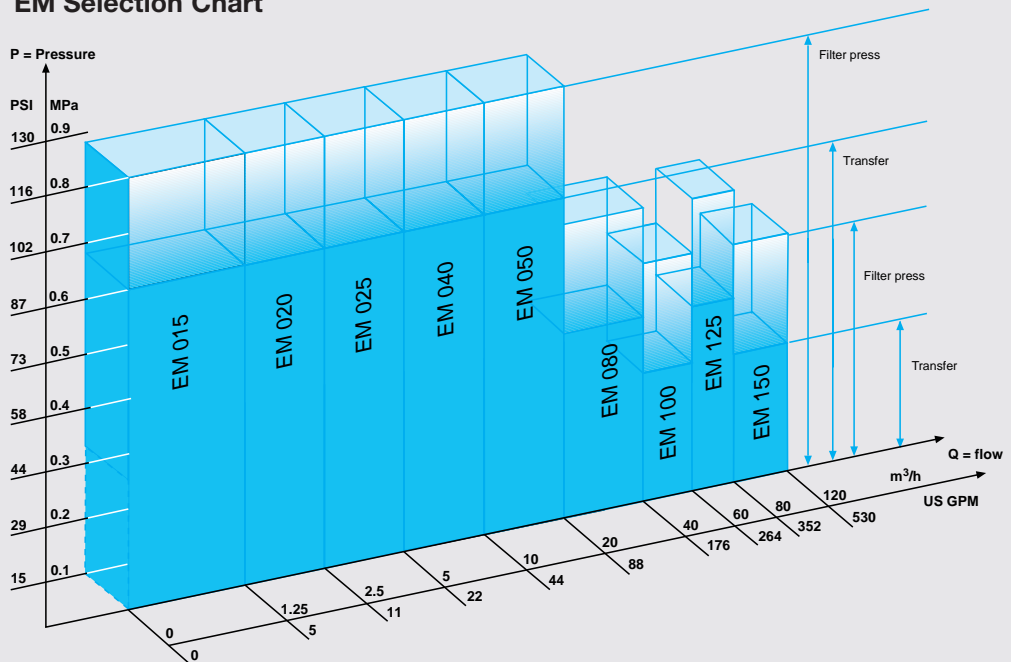

“Life-time” cost consideration

(5 years or 40,000 hours)

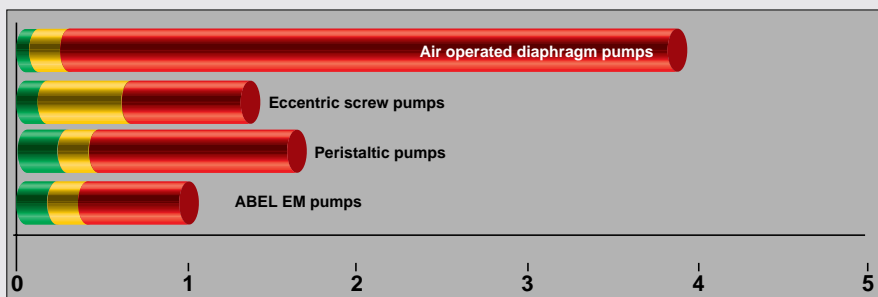

Legend: ■ Purchase price, ■ Wear part costs, ■ Energy costs

ABEL EM Metal

Capacity ranges to 530 GPM, Pressure up to 115 PSI

Robust Housing Construction:

- Ductile Iron (SG)
- Stainless Steel (ED)
- Aluminum (AL) (Contact ABEL)
- Food Grade Stainless (EF) (Contact ABEL)

Membrane/Ball/Seat Options:

- Nitrile/NBR
- EPDM
- Polyurethane (only balls and seats)
- FPM (Viton®)
- PTFE
- Flapper valves with seats of RCH to handle larger solids



ABEL EM Metal



ABEL EM Food

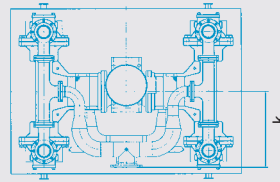
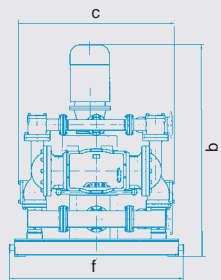
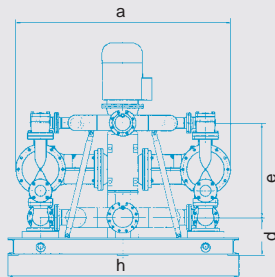
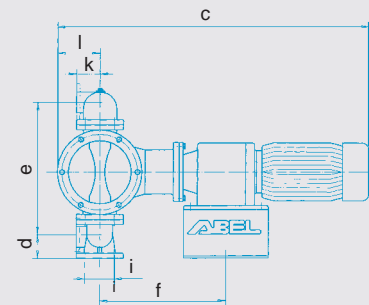
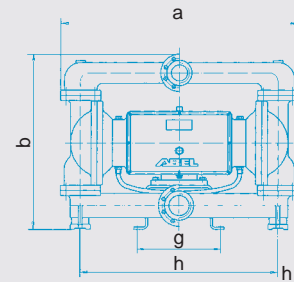

EM 125 – EM 150

EM 15 – EM 100

ABEL EM Model Size	15	20	25	40	50	80	100	125	150	
US GPM	5	11	22	45	90	175	260	350	525	
Cubic Meters per Hour	1,25 *)	2,5	5 *)	10 *)	20 *)	40	60	80	120	
Max. Strokes / Min	150	135	120	110	100	91	84	91	84	
Max. HP at 90PSI	0,5	1	2	4	7,5	15	25	30	50	
Max. kW at 0.6 MPa	0,37	0,75	1,5	3	5,5	11	18,5	22	37	
Nominal suction Width	0,75" T	1" T	1,5" T	2" T	3" ANSI	4" ANSI	6" ANSI	6" ANSI	8" ANSI	
Metric Suction Connections	G 3/4"	G 1"	G 1 1/2"	G 2"	DN 80	DN 100	DN 125	DN 150	DN 200	
Nominal Discharge Width	0,50" T	0,75" T	1" T	1,5" T	2" ANSI	3" ANSI	4" ANSI	6" ANSI	6" ANSI	
Metric Discharge Connections	G 1/2"	G 3/4"	G 1"	G 1 1/2"	DN 50	DN 80	DN 100	DN 125	DN 150	
Max. solide size - mm	3	4	6	8**)	10**)	12**)	15**)	12**)	15**)	
Number of pump chambers	2	2	2	2	2	2	2	4	4	
Approximate Weight kg	33	62	120	165	340	895	1750	2520	4160	
Dimensions in mm's										
a	346	450	535	611	795	1195	1706	1925	2350	a
b	256	320	402	507	772	965	1295	1869	2310	b
c	585	720	840	1010	1165	1710	2085	1250	1710	c
d	24	30	43	70	115	120	152	318	410	d
e	210	263	317	402	581	745	1023	745	1023	e
f	290	365	439	449	570	750	935	1350	1910	f
g	175	205	280	280	330	490	580	---	---	g
h	300	378	450	511	645	985	1365	---	---	h
i	80	100	135	165	260	210	250	---	---	i
k	30	30	40	56	100	125	180	755	830	k
l	68	88	108	133	168	220	270	---	---	l

* Reduce flow rate with PTFE membranes approximately 50% T = NPT Threaded connection standard (ANSI flanges optional)

** Approximately double allowable solid particle size when using optional flap valves for EM40 and larger models.

ABEL EM Plastic

Capacity ranges to 175 GPM, Pressure up to 115 PSI

For corrosive fluids

For chemical compatibility and cleanliness ABEL provides polypropylene (PP), PVDF (PV), polyurethane (PU) construction for its EM series pumps.

Explosion proof and environmentally suitable motors are standard package options for flow rates through 175 GPM.

Optional EM stainless steel food grade pumps are also available with the benefit of enabling easy rinsing and cleaning methods where required (Contact ABEL).

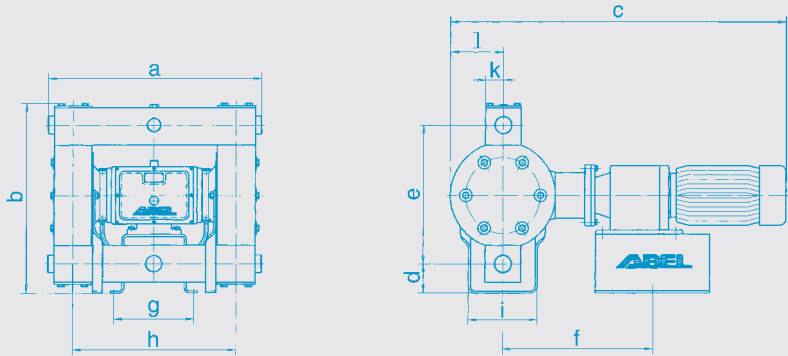

ABEL EM Pump Size	15	20	25	40	50	
US GPM	5	11	22	45	90	
Cubic Meters per Hour	1,25	2,5	5	10	20	
Max. Strokes / Min	150	135	120	110	100	
Max. HP at 90PSI	0,5	1	2	4	7,5	
Max. kW at 0.6 MPa	0,37	0,75	1,5	3	5,5	
Nominal suction Width	0,75" T	1" T	1,5" T	2" T	3" ANSI	
Metric Suction Connections	G 3/4"	G 1"	G 1 1/2"	G 2"	DN 80	
Nom. diam. of discharge connection	G 1/2"	G 3/4"	G 1"	G 1 1/2"	DN 50	
Metric Discharge Connections	G 1/2"	G 3/4"	G 1"	G 1 1/2"	DN 50	
Max. solide size - mm	3	4	6	8**)	10**)	
Approximate Weight kg	30	60	80	125	270	
Dimensions in mm's						
a	405	510	605	680	845	a
b	265	310	380	485	740	b
c	585	730	852	1023	1207	c
d	36	30	40	53	115	d
e	200	250	305	385	560	e
f	290	335	439	449	570	f
g	175	205	280	280	330	g
h	300	380	460	520	645	h
i	60	80	190	243	300	i
k	30	38	48	55	73	k
l	80	98	120	146	210	l
**) approx. 50% of the flow rate if PTFE membranes are used						

ABEL EM
 Electromechanical Membrane Pumps
 Energy Saving PD Performance for Process and Transfer

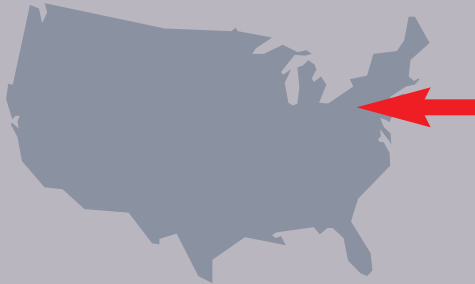

ABEL Pumps, L.P.
 79 N. Industrial Park
 207 Overlook Dr
 Sewickley, Pennsylvania
 PA 15143-2339 USA
 Tel: 412 741 3222
 Fax: 412 741 2599
 mail@abelpumps.com
 www.abelpumps.com

Accessories include:



Assistance:

The qualified staff of ABEL Pumps, L.P. is ready to assist you with your critical needs.

Please contact us with your specific requirements.

Services include:

- ▲ Start-up
- ▲ Training
- ▲ Installation
- ▲ Repair
- ▲ Warranty Contracts
- ▲ Upgrades
- ▲ Telephone Diagnostics
- ▲ On Site Repairs
- ▲ Part Kits
- ▲ Qualified Representatives for Local Assistance

Certifications:

- ▲ ISO 9001
- ▲ MIL-I-45208A Inspection Compliant

Helpful Information:

Company:	e-mail:
Address:	Tel./Fax:
	Contact:
Application:	Why needed?
	Temperature:
Fluid:	Sp. Gr.:
Flow Rate:	Pressure:
Solids? % & size:	Viscosity:
Operating Cycle:	Special Materials:

Combined Slurry:

% Solids 1) By Weight 2) By volume

Abrasivity (Miller Number) PH Value

Viscosity Describe consistency

Remarks:

Thank you for the opportunity to be of service! – ABEL Pumps, L.P.